

SONY specifies the raw material is SS-00259 the latest version of document requests, and purchased from the SONY specified raw materials suppliers.

1 2 3 4 5 6

REVISIONS					
LTR	DESCRIPTION	DATE	REV.	CHKD.	APVD.

Ground contact begin contact plug outer shell (Firstly)

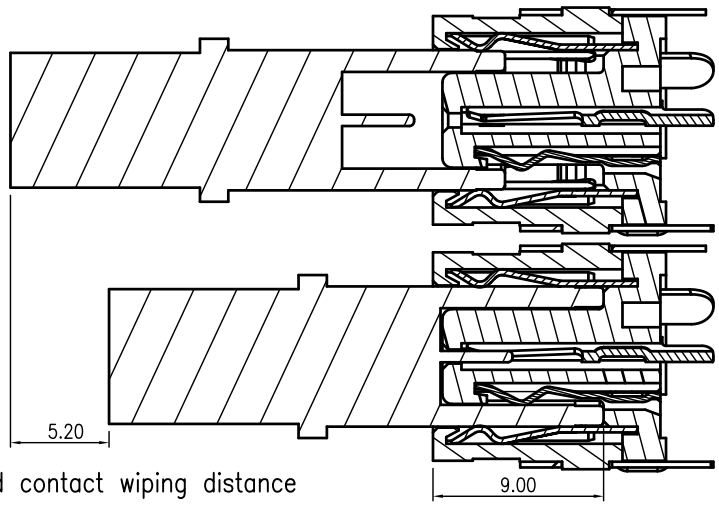

Ground contact wiping distance

Spring terminal begin contact plug inner shell (Secondly)

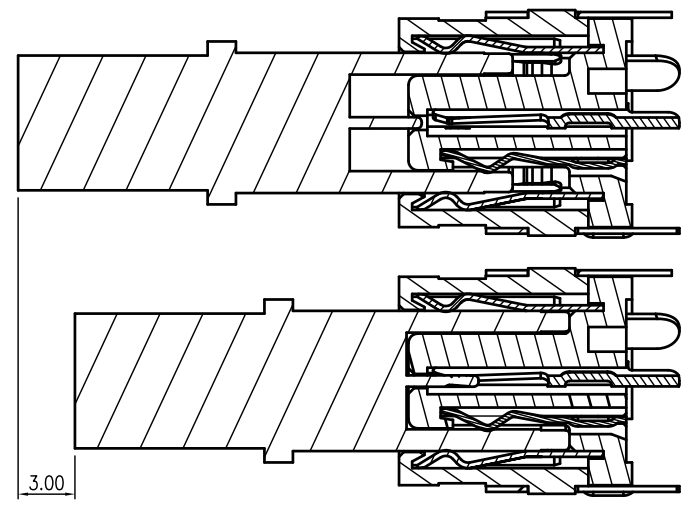

Spring terminal wiping distance

Terminal begin contact plug center pin (finally)

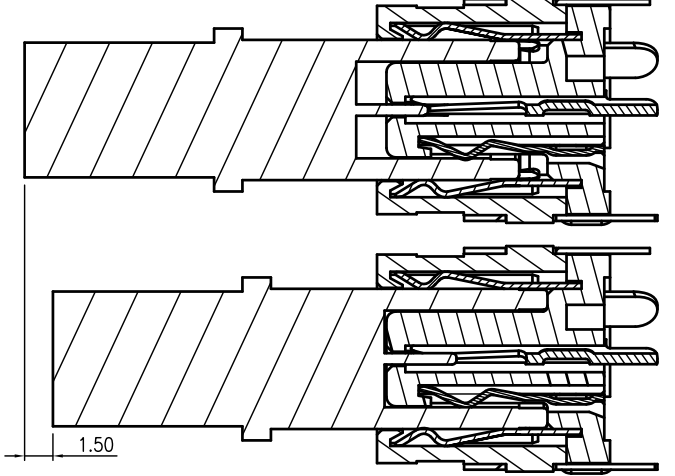

Terminal begin wiping distance

Plug mating connector simulation view

Contact sequence: Ground contact --> Spring terminal --> Terminal

7	KAPTON	1	Polyimide	
6	SEALED PLATE	1	Stainless Steel t=0.30	MBNi1 μm-Sn3 μm
5	TERMINAL (3)	1	Copper Alloy t=0.40	MBNi2 μm-Ag0.6 μm
4	SPRING TERMINAL (1)	1	Copper Alloy t=0.30	MBNi2 μm-Ag0.6 μm
3	GROUND CONTACT (2)	2	Copper Alloy t=0.30	MBNi2 μm-Ag0.6 μm
2	COVER	1	High Temperature Thermoplastic UL 94V-0	Black
1	HOUSING	1	High Temperature Thermoplastic UL 94V-0	Black

LTR	PART NAME	Q'TY	MATERIAL	REMARK
120~315	±0.50	DWN	李阮龍	DATE 2016.11.16
30~120	±0.35	DSND	李阮龍	DATE 2013.05.14
6~30	±0.22	CHKD	郭遠峰	DATE 2016.11.16
BELOW 6	±0.16	APVD	郭遠峰	DATE 2016.11.16
DIMENSION TOLERANCE				KUNMING ELECTRONICS CO.,LTD.
				SCALE 2.5/1
				PROJECTION
				UNIT:mm
				NAME DC JACK
				CAT. NO. KM02028DS1BML
				DWN.NO. A-02028DS1BML
				2/3
				001

SONY specifies the raw material is SS-00259 the latest version of document requests, and purchased from the SONY specified raw materials suppliers.

1

2

3

4

5

6

REVISIONS

LTR	DESCRIPTION	DATE	REV.	CHKD.	APVD.

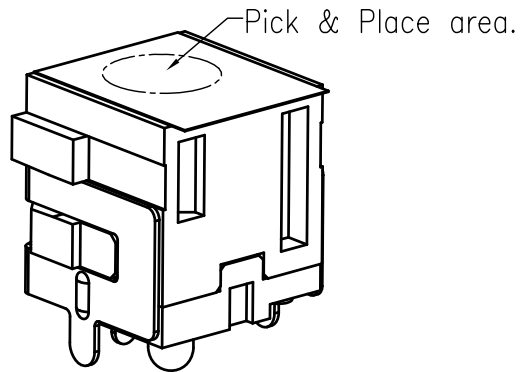

Before soldering process

Remove the kapton.

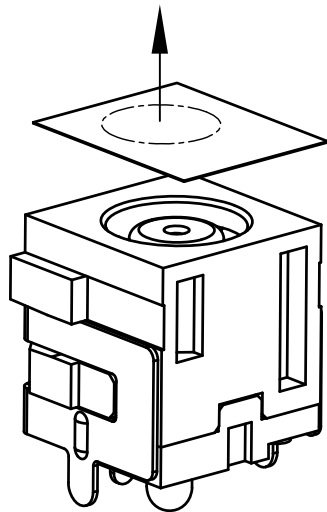

After soldering process

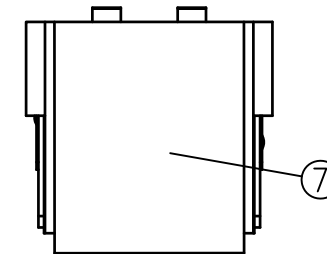
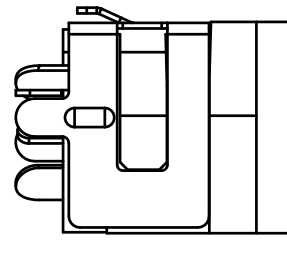

7	KAPTON	1	Polyimide	
6	SEALED PLATE	1	Stainless Steel t=0.30	MBNi1 μ m-Sn3 μ m
5	TERMINAL (3)	1	Copper Alloy t=0.40	MBNi2 μ m-Ag0.6 μ m
4	SPRING TERMINAL (1)	1	Copper Alloy t=0.30	MBNi2 μ m-Ag0.6 μ m
3	GROUND CONTACT (2)	2	Copper Alloy t=0.30	MBNi2 μ m-Ag0.6 μ m
2	COVER	1	High Temperature Thermoplastic UL 94V-0	Black
1	HOUSING	1	High Temperature Thermoplastic UL 94V-0	Black

LTR	PART NAME	Q'TY	MATERIAL	REMARK
120~315	± 0.50	DWN	李阮龍	DATE 2016.11.16
30~120	± 0.35	DSND	李阮龍	DATE 2013.05.14
6~30	± 0.22	CHKD	郭遠峰	DATE 2016.11.16
BELOW 6	± 0.16	APVD	郭遠峰	DATE 2016.11.16
DIMENSION TOLERANCE		KUNMING ELECTRONICS CO.,LTD.		
SCALE 2.5/1				NAME DC JACK
PROJECTION				CAT. NO. KM02028DS1BML
UNIT:mm				DWN.NO. A-02028DS1BML
				3/3 001

SONY specifies the raw material is SS-00259 the latest version of document requests, and purchased from the SONY specified raw materials suppliers.