

PCB Layout Dimension (Tolerance:±0.10)  
(Recommend min. Dimension)(Bottom View)

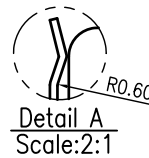

△ Approved Standard : UL&cUL File No E95834

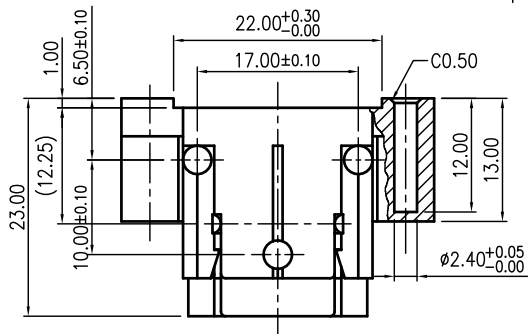
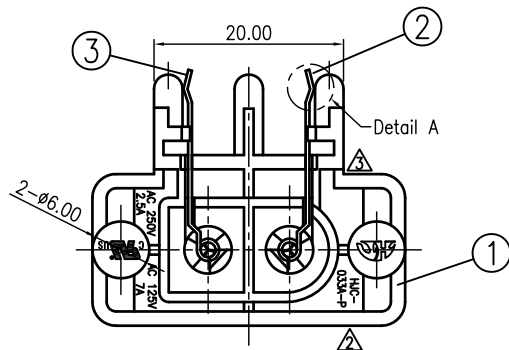

3	PIN 2	1	C2680R-1/2H t=0.40	MBCu-Sn
2	PIN 1	1	C2680R-1/2H t=0.40	MBCu-Sn
△ 1	HOUSING	1	PP0(SABIC N300)UL 94V-0	Black

LTR	PART NAME	Q'TY	MATERIAL	REMARK
120~315	±0.50	DWN	鄭伍豐	DATE 2008.07.16
30~120	±0.35	DSND	鄭伍豐	DATE 2008.07.16
6~30	±0.22	CHKD	陸昌妹	DATE 2008.07.17
BELOW 6	±0.16	APVD	蔡志祿	DATE 2008.07.17
DIMENSION	TOLERANCE	KUNMING ELECTRONICS CO.,LTD.		SCALE 1.25/1
				PROJECTION
				UNIT:mm
			DWN.NO.	1/1
			A-033A-P	D-001

UNLESS OTHERWISE SPECIFIED, TOLERANCE ON DECIMAL:±0.30 ANGLES:±5°

The raw material specified by Sony should meet SS-00259 requirement of the latest version. When such material is used, it should be supplied by Sony designated suppliers.