

REVISIONS					
LTR	DESCRIPTION	DATE	REV.	CHKD.	APVD.
△x2	Cancel the Semko mark (Semko Reference No)	2018.01.30	李阮龍	郭遠峰	郭遠峰

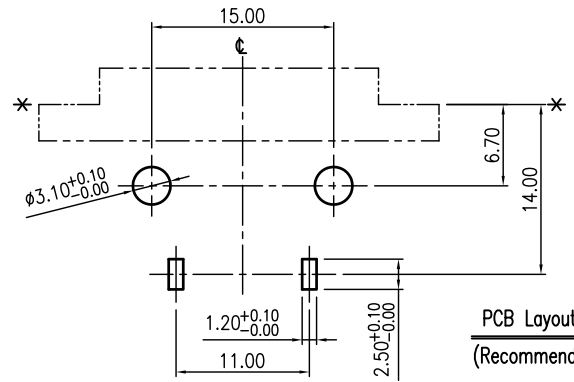
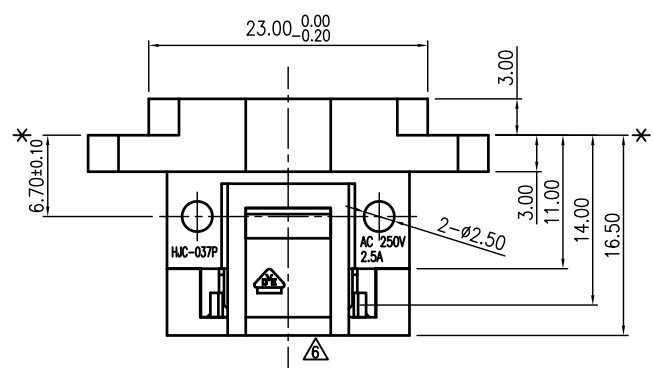
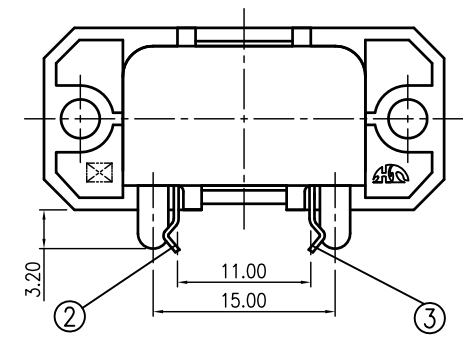
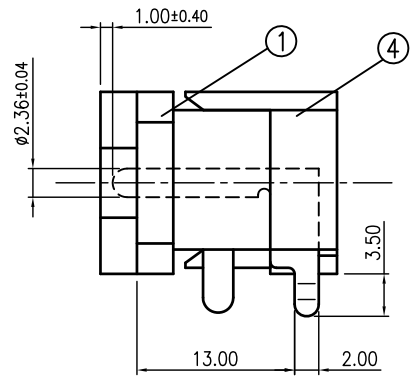
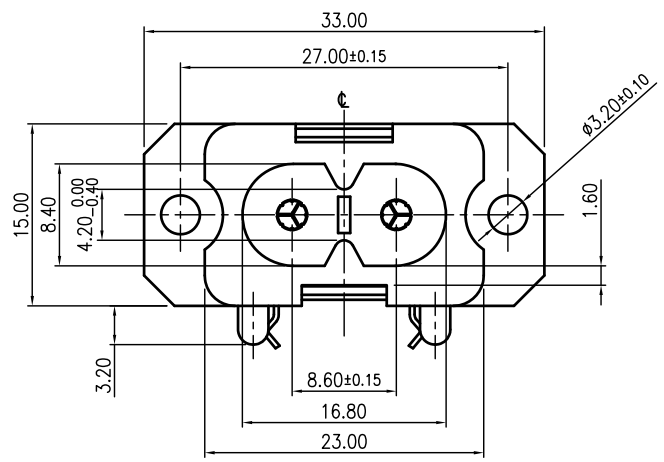

PCB Layout Dimension (Tolerance:±0.10)
(Recommend min. Dimension)(Bottom View)

4	COVER	1	PPO(N300) UL 94V-0	Black
3	PIN	1	C2680R t=0.40	MBCu2-Sn3 plated
2	PIN	1	C2680R t=0.40	MBCu2-Sn3 plated
1	HOUSING	1	PPO(N300) UL 94V-0	Black

LTR	PART NAME	Q'TY	MATERIAL	REMARK
120~315	±0.50	DWN	蘇建源	DATE 2003.02.20
30~120	±0.35	DSND	蘇建源	DATE 2003.02.20
6~30	±0.22	CHKD	夏正雄	DATE 2003.02.20
BELOW 6	±0.16	APVD	楊仲民	DATE 2003.02.20
KUNMING ELECTRONICS CO.,LTD.				DWN.NO. A-037P
				1/1
				F

△ Approved Standard:
VDE Certificate No.40004998

DIMENSION	TOLERANCE
120~315	±0.50
30~120	±0.35
6~30	±0.22
BELOW 6	±0.16

UNLESS OTHERWISE SPECIFIED, TOLERANCE ON DECIMAL: ±0.30 ANGLES: ±5°

SONY specifies the raw material is SS-00259 the latest version of document requests, and purchased from the SONY specified raw materials suppliers.